

# DLF57 Series Planetary Gear Reducer

Standard Precision for Stepper Motors

## Mechanical Dimensions in mm

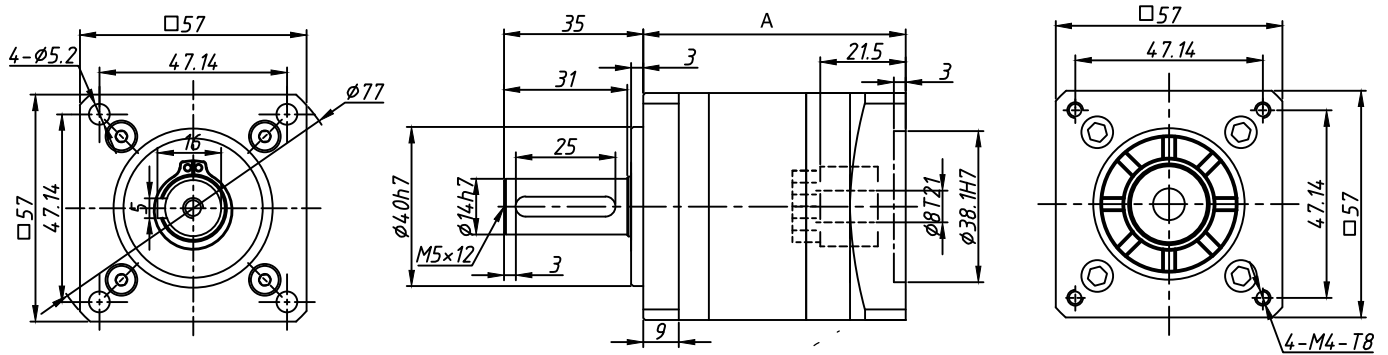

Note: Customizable to match with all motors.

## Specifications

| Stage                     | 1-Stage                            |      |      |     | 2-Stage   |    |    |    |    |    |    |      | 3-Stage   |      |      |      |      |     |      |  |
|---------------------------|------------------------------------|------|------|-----|-----------|----|----|----|----|----|----|------|-----------|------|------|------|------|-----|------|--|
| Length of A (mm)          | 55(66)                             |      |      |     | 70(81)    |    |    |    |    |    |    |      | 85(96)    |      |      |      |      |     |      |  |
| Reduction Ratio           | 4                                  | 5    | 7    | 10  | 16        | 20 | 25 | 28 | 35 | 40 | 50 | 70   | 64        | 80   | 100  | 125  | 140  | 175 | 200  |  |
| Rated Output Torque (N.m) | 27                                 | 29.5 | 19.5 | 8.5 | 30        | 30 | 33 | 30 | 33 | 30 | 33 | 21.5 | 37.5      | 37.5 | 37.5 | 37.5 | 37.5 | 41  | 37.5 |  |
| Max. Output Torque (N.m)  | 54                                 | 59   | 39   | 17  | 60        | 60 | 60 | 60 | 66 | 60 | 66 | 66   | 75        | 75   | 75   | 75   | 75   | 82  | 82   |  |
| Fullload Efficiency (%)   | 96%                                |      |      |     | 94%       |    |    |    |    |    |    |      | 90%       |      |      |      |      |     |      |  |
| Backlash                  | <20arcmin                          |      |      |     | <30arcmin |    |    |    |    |    |    |      | <50arcmin |      |      |      |      |     |      |  |
| Weight (kg)               | 0.8                                |      |      |     | 1.0       |    |    |    |    |    |    |      | 1.3       |      |      |      |      |     |      |  |
| Average Lifetime (H)      | > 20000                            |      |      |     |           |    |    |    |    |    |    |      |           |      |      |      |      |     |      |  |
| Lubrication               | Long-term Effective Grease         |      |      |     |           |    |    |    |    |    |    |      |           |      |      |      |      |     |      |  |
| Rotation Direction        | Input Output Same Direction        |      |      |     |           |    |    |    |    |    |    |      |           |      |      |      |      |     |      |  |
| Working Temperature       | -10 <sup>0</sup> ~+80 <sup>0</sup> |      |      |     |           |    |    |    |    |    |    |      |           |      |      |      |      |     |      |  |
| Installation              | Any                                |      |      |     |           |    |    |    |    |    |    |      |           |      |      |      |      |     |      |  |